

Gate Valves

For Australian Waterworks

Gate valves are on-off valves and are designed for the primary function of flow isolation.

Gate valves feature a sliding partition that can be closed to block flow or opened fully for maximum flow. Gate valves are used to isolate sections of pipelines, branch off-takes and pieces of equipment. They are on-off valves designed for the primary function of flow isolation and should only be operated in the fully closed or fully open positions. The sliding motion of the gate is effected by a rotating screw, known as a spindle or stem.

Sluice valves are gate valves and prior to the introduction of fusion bonded coatings they were of a heavier construction to endure buried service applications, whereas gate valves were associated with above ground applications. Today's modern coating systems remove the need for distinction between buried and above ground applications and therefore no need for sluice valve and gate valve distinction.

There is a growing industry trend to use gate valves in flow regulating and scour applications. When gate valves are used in these applications it is essential that they are operated in the fully opened position and any regulation of flow controlled by other means, such as orifice plates.



Orifice plates choke the flow and reduce head loss across the gate valve thus preventing valve damage.

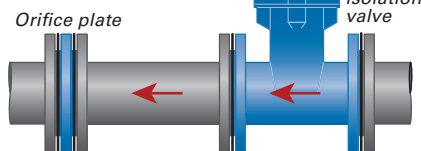

Gate valves should not be used for throttling or adjusting flow as associated turbulence and high velocity can lead to vibration, chattering and fretting wear, as well as cavitation damage of the valve and downstream pipeline.

When used as a control or modulating valve this can also lead to these problems, the installation of a secondary valve for isolation purposes is recommended.

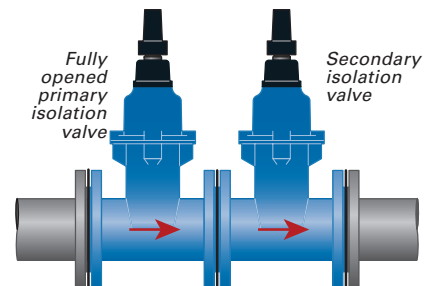

Secondary isolation valve used for control or modulating purposes. Primary isolation valve used for isolation purposes only.

When throttling is necessary, globe or butterfly valves should be used.

Design options

There are two design options for Gate Valves, Metal Seated and Resilient Seated. These two options can also be split into two categories Non-Rising Spindle (Inside Screw) and Rising Spindle (Outside Screw).

Non-Rising Spindle Gate valves are suitable for above ground and underground installations but are used predominately in underground installations because spindle movement is rotational only and additional cover is not required to accommodate the opened valve.

Rising Spindle Gate valves are predominately used for above ground and valve pit installations. They are commonly used in fire service applications where a positive indication of the open or closed position is necessary. Tyco's range of Gate Valves employs an articulated gate design where the wedge nut is located separately within a housing in the gate. This articulated gate design has key advantages over systems where the stem nut is integral with the gate. It overcomes the risk of damage through direct pressure on the stem, stem nut or other components during operation or transitional throttling.

Tyco does not recommend the use of gate valves for end of line isolation. If the valves are to be fitted to the end of a line we recommend the use of a blank flange or plug to ensure isolation of the line.



Metal seated gate valves

Metal seated gate valves comprise a metal gate, typically wedge shaped and made of gunmetal for valves up to and including 200mm and ductile iron with gunmetal sealing rings for larger sizes. The gate and body are fitted with metal sealing rings by threading or plastic deformation to prevent loosening in service. A continuous seal is provided behind the rings to prevent corrosion. The valve is closed by appropriate rotation of the spindle which drives the gate down between the sealing rings. Sealing is effected by the mating of the sealing rings. Sometimes the sealing surfaces can become damaged from the impact of foreign debris or from foreign debris being lodged between the sealing faces. Throttling of a metal seated gate valve is the most common cause of damage to the sealing faces. Repair of the sealing surfaces is not a simple operation and a factory refit is normally necessary.

In metal seated gate valves, maximum torque on the spindle is associated with initial opening



or 'cracking' of the valve. Properly operated and closed, these valves can effect a drop tight seal but leakage rates of 2-10 ml/min are acceptable under AS 2638.1.

Resilient seated gate valves

Resilient seated gate valves contain an EPDM rubber encapsulated ductile iron gate. The valve is closed by appropriate rotation of the spindle which drives the gate against the cast internal sealing surfaces of the valve body. These surfaces are normally coated with fusion bonded polymers such as epoxy or nylon.

Sealing is achieved by the compression of the EPDM rubber coating on the gate against the valve body. In resilient seated gate valves, maximum torque of the spindle is associated with closing the valve to overcome the effects of friction and compression of the EPDM rubber coating. Properly operated and closed, these valves can effect a drop tight seal. The gate is body guided throughout the major portion of its closure and secondary guides become effective near the end of its travel to ensure correct seat alignment.



Throttling

When gate valves are fully opened their head loss coefficient K_L is in order of 0.12.

Note the flow through the valve is not directly proportional to the number of turns of the valve spindle.

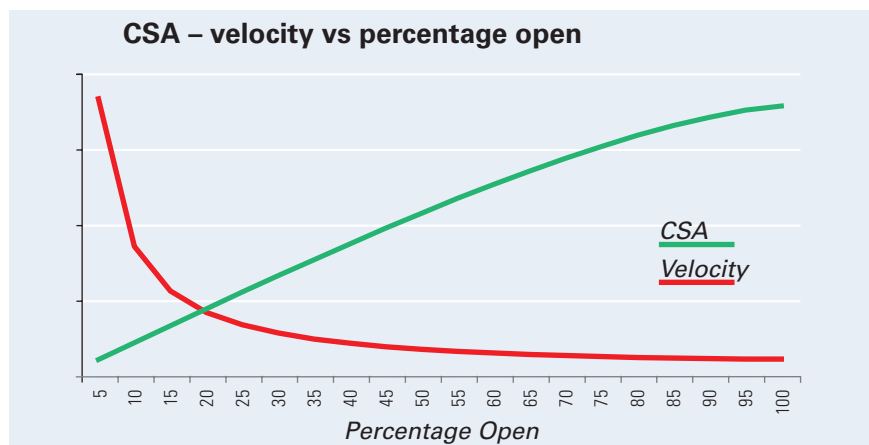

Below ground gate valves

Figure 500 resilient seated

- Ductile iron body and bonnet for high strength and impact resistance
- Ductile iron gate fully encapsulated in EPDM rubber to ensure drop tight sealing
- Grade 431 Stainless Steel spindle for high strength and corrosion resistance
- Gunmetal dezincification resistant top casting incorporating dual O-ring seals and wiper ring for long life operation
- Back seal facility to allow for replacement of seals under full operating pressure
- Rilsan® Nylon 11 coating for long life corrosion protection
- Straight through full bore to avoid debris traps
- Isolated fasteners for corrosion protection
- Anti-friction thrust washer for low operating torques
- Integral cast in feet for safe and easy storage
- Integral lifting lugs for installation convenience
- Anticlockwise closing or clockwise closing available
- Key, handwheel or gearbox operation available



AUSLITE resilient seated

- Ductile Iron body and bonnet for high strength and impact resistance
- Ductile Iron gate fully encapsulated in EPDM elastomer to ensure drop tight sealing
- Grade 431 stainless steel spindle for high strength and corrosion resistance
- Seal housing incorporates dual o-ring seals and wiper ring for long life operation
- Back seal facility to allow for replacement of seals under full operating pressure
- Fusion bonded polymeric coating for long life corrosion protection
- Straight through full bore to avoid debris traps
- Isolated fasteners for corrosion protection
- Anti-friction guide liners for low operating torques
- Integral cast-in feet for safe and easy storage
- Anticlockwise closing or clockwise closing available
- Key or hand wheel operation



Figure 400 metal seated

- Ductile Iron body and bonnet for high strength and impact resistance
- Solid gunmetal gate for DN 80 - DN 200, ductile iron fusion coated gate with gunmetal rings for larger sizes TWS400/1/07
- Grade 431 stainless steel spindle for high strength and corrosion resistance
- Gunmetal dezincification resistant top casting incorporating dual o-ring seals and wiper ring for long life operation
- Back seal facility to allow for replacement of seals under full operating pressure
- Thermally bonded polymeric coating for long life corrosion protection
- Isolated fasteners for corrosion protection
- Anti-friction thrust washer for low operating torques
- Integral cast in feet for safe and easy storage
- Integral lifting lugs for installation convenience
- Anticlockwise closing or clockwise closing available
- Key, handwheel or gearbox operation available



Above ground gate valves

Figure 500H + 500R resilient seated

- Ductile Iron body and bonnet for high strength and impact resistance
- Ductile iron gate fully encapsulated in EPDM rubber to ensure drop tight sealing
- Grade 431 stainless steel spindle for high strength and corrosion resistance
- Gunmetal dezincification resistant top casting incorporating dual O-ring seals and wiper ring for long life operation
- Back seal facility to allow for replacement of seals under full operating pressure
- Thermally bonded polymeric coating for long life corrosion protection
- Straight through full bore to avoid debris traps
- Isolated fasteners for corrosion protection
- Anti-friction thrust washer for low operating torques
- Integral cast in feet for safe and easy storage
- Integral lifting lugs for installation convenience
- Hand wheel operation

Figure 600H + 601 metal seated

- Ductile Iron body and bonnet for high strength and impact resistance
- Solid gunmetal gate for DN 80 – DN 200, ductile iron fusion coated wedge with gunmetal rings for larger sizes
- Grade 431 stainless steel spindle for high strength and corrosion resistance
- Gunmetal dezincification resistant top casting incorporating dual O-ring seals and wiper ring for long life operation
- Back seal facility to allow for replacement of seals under full operating pressure
- Thermally bonded polymeric coating for long life corrosion protection
- Isolated fasteners for corrosion protection
- Anti-friction thrust washer for low operating torques
- Integral cast in feet for safe and easy storage
- Integral lifting lugs for installation convenience
- Hand wheel operation



Tyco Water gate valves technical data

		Below ground			Above ground	
		Fig 400	Fig 500	AUSLITE	Fig 500H Fig 500R	Fig 600 Fig 601
Class	PN	16 or 35	16	16 or 25	16	16
Size range	DN	80 - 900 ¹	80 - 600	80 - 150	80 - 300	80 - 300
Allowable operating temperature (AOP)	°C	40	40	40	40	40
End connections						
Flanged – AS 2129 TE		✓	✓	✓	✓	✓
– AS 4087 Fig B5		✓	✓	✓	✓	✓
– AS 4087 Fig B6		✓	✓ ²	✓ ³		
<i>Note: ISO, ANSI and other drillings available on request.</i>						
TYTON JOINT						
– Socket		✓ ⁴	✓ ⁷	✓ ¹⁰		
– Spigot – AS/NZS 2280		✓ ⁵	✓ ⁸	✓		
Shouldered		✓ ⁶		✓ ¹¹		
Flange/Socket			✓ ⁹	✓		
Approvals						
WSAA Appraisal No. 98/21		✓	✓			
ISC AS 2638 Product Mark Reg. No. PRD/R61/0412/2		✓ ¹²	✓	✓	✓	✓
Certified to AS 4020 – suitable for contact with drinking water		✓	✓	✓	✓	✓

Notes.

- DN 900 High Pressure Fig400 Valves are rated to PN 25.
- PN 25 Fig 500 Valves are available in DN 100 and DN 150 sizes in flanged versions only.
- PN 25 Auslite Valves are available in flanged versions only.
- Fig 400 Socket Valve available in DN 100 – DN 250 sizes only.
- Fig 400 Spigot Valves available in DN 100 and DN 150 sizes only.
- Fig 400 Shouldered Valves available in DN 100 and DN 150 sizes only.
- Fig 500 Socket Valves available in DN 100 – DN 375 sizes only.
- Fig 500 Spigot Valves available in DN 80 – DN 300 sizes only.
- Fig 500 Flange/Socket Valves available in DN 80 – DN 300 sizes only.
- AUSLITE Socket Valves available in DN 100 and DN 150 sizes only.
- AUSLITE Shouldered Valves available in DN 100 and DN 150 sizes only.
- ISC Approvals for DN 80 – DN 750 sizes only.



Gearboxes

Gate valves are normally supplied without gearing. Gearboxes are fitted when the operator applied spindle torque (turning moment) is greater than that which can be reasonably achieved manually by field staff. These torque thresholds may be set by Operator, OH&S or legislative requirements.

The need for a gearbox is determined by:

- operating pressure
- valve diameter
- differential pressure across the gate
- valve orientation in service – horizontal or vertical
- maximum operator input torque
- maximum possible input torque to the valve

Where gearboxes are required, sizes DN 250 to DN 600 valves are supplied with single input shaft. For DN 750 to DN 900 valves, dual input shafts with a dial indicator are fitted. Dial indicators are not suitable for open weather installations.

Please contact your local Tyco Water Regional Marketing Office for advice.

Torque requirements of metal seated gate valves

The figure below shows how torque (spindle turning force) varies as a MSGV is opened and closed.

If there is a differential head across the gate in the closed position the initial opening torque, also known as the 'cracking' torque is very high. This is due to the additional friction component generated between the body sealing rings and gate sealing rings by the unbalanced pressure. As the valve is opened, the torque falls rapidly as the differential head across the valve drops off. The 'opening' torque corresponds to the spindle turning force required to overcome continued opening and final friction of the gate sealing rings. The torque continues to fall to a constant value known as the 'running' torque or 'functional' torque where the operational torque is at a minimum. 'Closing' torque is much less than the 'cracking' torque. When closing a metal seated gate valve it should be remembered that sealing is effected by unbalanced pressure against the wedge rings bearing against the body rings. Backing off of the stem by ½ turn after full closure may be necessary to settle the rings into a fully seated and mated position.

Gearbox sizing for metal seated gate valves

Gearbox sizing based on the cracking torque is not recommended as the resulting high ratio gearboxes make operating times very long. Gearboxes should preferably be sized on the running torque as the 'cracking' torque is only required for initial opening of the valve and lasts for 1/4 to 1 turn of the spindle.

It should be noted however that torques in excess of the minimum strength test torque may damage the valve.

Where high ratio gearboxes are necessary, torque limiting devices should be considered.

Determining 'running' torque is difficult and use of 'maximum functional test torque' to size the gearbox is common. Sizing the gearbox on running or functional torque may require torque in excess of the nominated maximum operator input torque to crack the valve. Cracking torque may be overcome with a longer bar, torque multiplier or more operators.

Standard gearbox ratios include 2:1, 4:1, 6:1, 12:1, 16:1 and 24:1.

High ratio gearboxes require low operating torques but require extra turns to operate the valve and increase risk of valve damage due to excessive input torque.

Low ratio gearboxes reduce the risk of damage and require less turns to operate the valve but require high input torques, particularly for cracking.

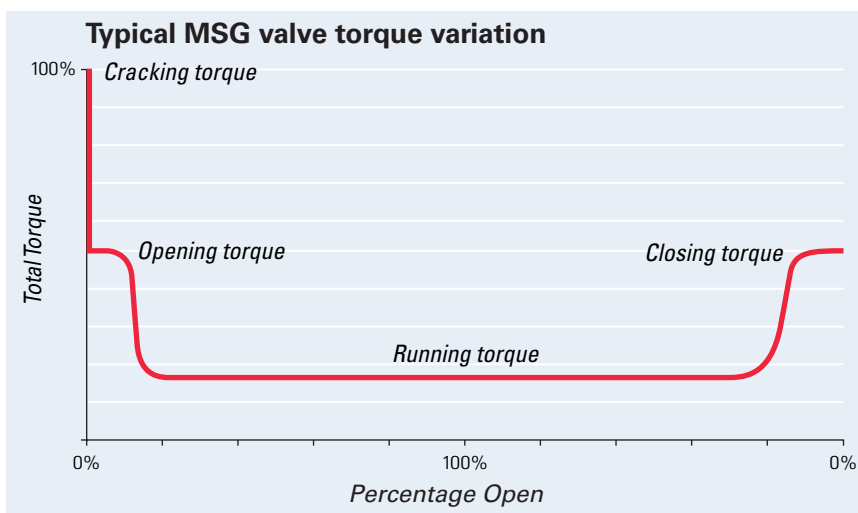

Gearboxes

Minimum required gearbox ratio for metal seated gate valves, G

$$G = T_f / (T_m E)$$

G = minimum required gearbox ratio, rounded up to 2, 4, 6, 12, 16, 24

T_f = maximum functional test torque or running torque

E = gearbox efficiency, single reduction spur = 0.90; single reduction bevel = 0.85

T_m = maximum operator input torque

Example

DN 450 PN16 metal seated gate valve coupled with spur gearbox

T_f = 425Nm (maximum functional test torque – AS2638.1)

E = 0.90

T_m = 150Nm (assumed maximum operator input torque)

G = $425 / (150 \times 0.90)$
= 3.14

Maximum required gearbox ratio,

G = 4 (rounded up)

Maximum allowable gearbox input torque for metal seated gate valves

$$T_{mg} = T_{ms} / (GE)$$

T_{mg} = maximum allowable gearbox input torque

G = selected gearbox ratio

E = gearbox efficiency

T_{ms} = minimum strength torque test

Example

DN 450 PN16 metal seated gate valve coupled with spur gearbox

T_{ms} = 1275Nm (minimum strength torque test – AS2638.1)

E = 0.90

G = 4 (from above example)

T_{mg} = $1275 / (4 \times 0.9)$
= 354Nm

Maximum allowable gearbox input torque = 354Nm

Final check for metal seated gate valves

Check to ensure that cracking the valve is possible with torques less than T_{mg} with the selected gearbox ratio. If T_{mg} is practicable, it can be assumed the valve can be cracked with the chosen gearbox even though an applied input torque is larger than the specified maximum operator input torque. This is because cracking torque is always less than minimum strength test torque.

If T_{mg} is greater than a practicable input torque, the gearbox output torque should be calculated, based on the maximum possible input torque.

$$T_{go} = T_p G E$$

T_{go} = gearbox output torque

T_p = maximum possible input torque

G = gearbox ratio

E = gearbox efficiency

T_{go} should be greater than the nominated cracking torque. If not, a higher ratio gearbox should be selected and T_{mg} recalculated. Repeat the process until T_{mg} is accepted as a practicable input torque OR until T_{go} is greater than the nominated cracking torque.

Example

DN 450 PN16 metal seated gate valve coupled with spur gearbox.

(Calculated cracking torque for a DN 450 PN16 metal seated gate valve at 1600kPa is 520Nm)

T_p = 250Nm (assumed maximum possible input torque)

E = 0.90

G = 4 (from above example)

T_{go} = $250 \times 4 \times 0.9 = 900\text{Nm}$

Gearbox output torque = 900Nm, which is greater than the calculated cracking torque of 520Nm. Therefore gearbox selection is acceptable.

Torque requirements of resilient seated gate valves

The figure on page 8 shows how torque (spindle turning force) varies as a RSGV is opened and closed.

The torque to seal a resilient seated valve is significantly higher than the torque to open. During opening the torque to operate reduces as the differential head across the gate reduces. The opening torque is also assisted by decompression of the EPDM Rubber encapsulating the gate. Finally a steady state is reached at a minimum, known as the running torque. Maximum torque for resilient seated gate valves is experienced on closing as the EPDM rubber coated wedge is compressed against the sealing interface in the valve body. The torque required to effect a full seal increases as friction and the compression increases at the end of travel of the gate.



Gearboxes

Gearbox sizing for resilient seated gate valves

Gearbox sizing based on torque to seal is not recommended as the resulting high ratio gearboxes make operating times very long. Gearboxes should preferably be sized on running torque as torque to seal is only required during closing of the valve and lasts for ¼ to 1 turn of the spindle.

It should be noted however that torques in excess of the minimum strength test torque may damage the valve.

Where high ratio gearboxes are necessary, torque limiting devices should be considered.

Determining 'running' torque is difficult and use of 'maximum functional test torque' to size the gearbox is common. Sizing the gearbox on running or functional torque may require torque in excess of the nominated maximum operator input torque to seal the valve. Sealing torque may be overcome with a longer bar, torque multiplier or more operators.

Standard gearbox ratios include 2:1, 4:1 and 6:1.

High ratio gearboxes require low operating torques but require extra turns to operate the valve and increase risk of valve damage due to excessive input torque.

Low ratio gearboxes reduce the risk of damage and require less turns to operate the valve but require high input torques, particularly for sealing.

Minimum required gearbox ratio for resilient seated gate valves, G

$$G = T_f / (T_m E)$$

G = minimum required gearbox ratio, rounded up to 2, 4, 6

T_f = maximum functional test torque or running torque

E = gearbox efficiency, single reduction spur = 0.90; single reduction bevel = 0.85

T_m = maximum operator input torque

Example

DN 450 PN16 resilient seated gate valve coupled with spur gearbox

T_f = 540Nm (running torque)

E = 0.90

T_m = 150Nm (assumed maximum operator input torque)

$$G = 540 / (150 \times 0.90) = 4$$

Maximum required gearbox ratio,

$$G = 4$$

Maximum allowable gearbox input torque for resilient seated gate valves

$$T_{mg} = T_{ms} / (GE)$$

T_{mg} = maximum allowable gearbox input torque

G = selected gearbox ratio

E = gearbox efficiency

T_{ms} = minimum strength torque test

Example

DN 450 PN16 resilient seated gate valve coupled with spur gearbox

T_{ms} = 1800Nm (minimum strength torque test – AS 2638.2)

E = 0.90

G = 4 (from above example)

T_{mg} = 1800 / (4x0.9) = 500Nm

Maximum allowable gearbox input torque = 500Nm

Final check for resilient seated gate valves

Check to ensure that the torque to seal the valve is possible with torques less than T_{mg} with the selected gearbox ratio. If T_{mg} is practicable, it can be assumed the valve can be sealed with the chosen gearbox even though an applied input torque is larger than the specified maximum operator input torque. This is because torque to seal is always less than minimum strength test torque.

If T_{mg} is greater than a practicable input torque, the gearbox output torque should be calculated, based on the maximum possible input torque.

$$T_{go} = T_p G E$$

T_{go} = gearbox output torque

T_p = maximum possible input torque

G = gearbox ratio

E = gearbox efficiency

T_{go} should be greater than the nominated torque to seal. If not, a higher ratio gearbox should be selected and T_{mg} recalculated. Repeat the process until T_{mg} is accepted as a practicable input torque OR until T_{go} is greater than the nominated sealing torque.

Example

DN 450 PN16 resilient seated gate valve coupled with spur gearbox (assume nominated torque to seal is equal to the maximum functional test torque)

T_p = 250Nm (assumed maximum possible input torque)

E = 0.90

G = 4 (from above example)

$$T_{go} = 250 \times 4 \times 0.9 = 900\text{Nm}$$

Gearbox output torque = 900Nm, which is greater than the maximum functional test torque of 600Nm. Therefore gearbox selection is acceptable.

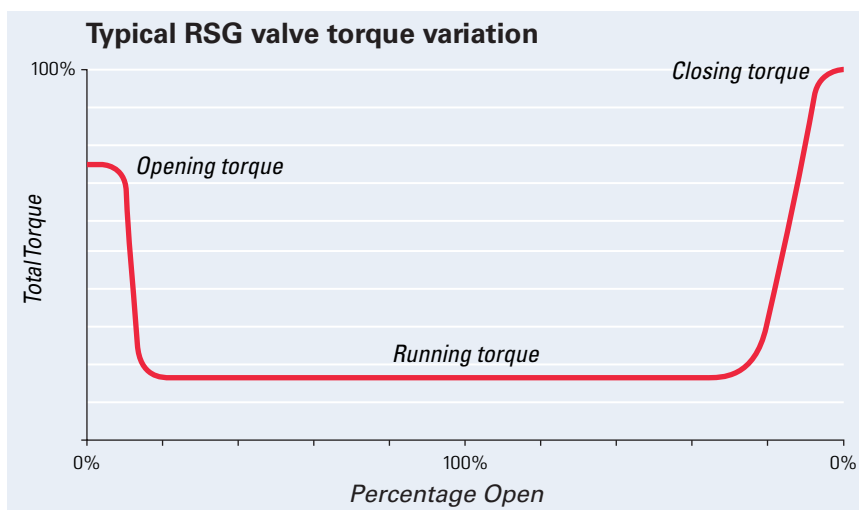

Identification of closing direction



Black cap
Indicates anti-clockwise closing.



Red cap
Indicates clockwise closing.



Handwheel
An arrow on the top of a handwheel also indicates the closing direction.

Valve end connections



Flange - Flange
DN 80 – DN 900



Flange - Socket
DN80 – DN300



Socket - Socket
DN100 – DN375



Spigot - Spigot
DN80 – DN300



Shouldered end
DN100, DN150



Troubleshooting

Leakage

Solution

Check and confirm that the appropriate torque has been applied to the valve spindle.

Service the following areas as applicable:

Spindle

The spindle seals are elastomeric O-rings. They can be replaced while the valve remains in-line under pressure by opening the gate fully.

Seat

■ MSGV: Foreign matter may be trapped between the wedge and body sealing rings. A leak in the 6 o'clock position suggests the gate has not been fully homed. Close the valve fully to the recommended closing torque. If the leak persists, open the valve just a little to allow a high velocity flow to flush the debris from the seat. This process may have to be repeated several times. A leak in the 12 o'clock position suggests the gate has been overtightened. It may be necessary to back the stem off by a ½ turn to allow the rings to settle into the fully seated and mated position. Failing this, open the valve and check for damage to the body and gate sealing rings. If damaged, return the valve to Tyco Water for repair.

■ RSGV: As for MSGV except for gate inspection, check EPDM rubber encapsulated wedge. If it is damaged or severely cut, replace the wedge.

Bolted connections

Inspect for loose bonnet-to-body screws or spindle seal retainer screws and tighten as necessary with gate in open position. If the line is pressurized, pressure should be relieved prior to tightening any screws. Reinstall all screws and tighten alternately to the recommended torque. Do not tighten screws past their yield strength. After successfully passing hydro test, reinstate fastener sealant.

Leakage during testing

Solution

Resilient seated gate valves per AS 2638.2 have a zero allowable leakage rate. Metal seated gate valves have an allowable leakage defined in AS 2638.1 Table 5.2.

If seat leakage is detected, it may be due to trapped air or foreign material in the line. Open the valve enough to get high velocity flow to flush out valve. Repeat several times until leakage stops.

If testing between valves, allow enough time to fill the pipeline and vent off air.

If pressure testing requirements exceeds AOP of valve, testing should be carried out with the gate in open position to prevent damage to the valve.

Class of valve PN	Allowable Operating Pressure kPa
16	1600
25	2500
35	3500

Valve service effects

Solution

Over-torquing can permanently damage the operating parts of a valve. Over-torquing commonly results from misuse of portable actuators. These machines should be adjusted to ensure the output torque is suitable for the valve size. The cracking/opening turns should be done manually and the actuator applied for the running torque only.

If valve has not been operated periodically, excessive buildup could occur that would affect valve operation. The valve should be exercised one turn at a time and cycled from open to closed as necessary to attempt removal of internal buildup.



AUSLITE RSGV parts list

No	Description Material / Standard
1	Body Ductile Iron / Fusion Polymeric Coated AS 1831 400-15 min / AS 4158
2	Bonnet Ductile Iron / Fusion Polymeric Coated AS 1831 400-15 / AS 4158
3	Retaining Plate Stainless Steel ASTM A276 316 / 431
4	Wedge Ductile Iron (EPDM Encapsulated) AS 1831 400-15 min
5	Stem Stainless Steel ASTM A276 431
6	Stem Cap Ductile Iron / AS 1831 400-15 min
7	Backseal / Collar Retainers Copper Alloy – Dezincification Resistant / AS 1567 C48600 min / C69300 min
8	Body Gasket EPDM / AS 1646
9	Top Gasket EPDM / AS 1646
10	Wedge Nut Copper Alloy – Dezincification Resistant / AS 1567 C48600 min
11	Counter Sunk Screw and Isolation Stainless Steel / ASTM A276 316 / Silicon
12	Socket Head Cap Screw and Isolation Stainless Steel / ASTM A276 316 / Silicon
13	Stem Cap Retaining Screw Stainless Steel / ASTM A276 316
14	O-Ring Nitrile Rubber / AS 1646
15	Wiper Ring EPDM / AS 1646
16	Collet Set / Copper Alloy – Dezincification Resistant AS 1567 C69300 min
17	Backseal Ring Nitrile Rubber / AS 1646 min

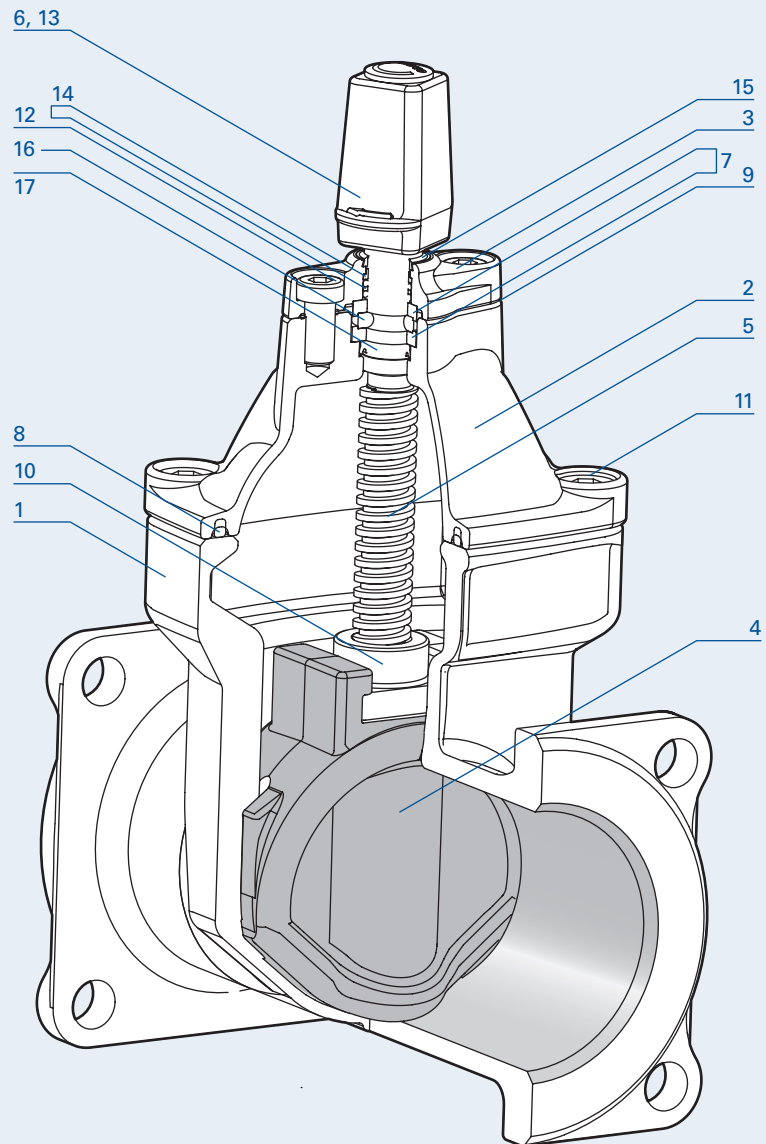

Metal seated gate valve parts list

No	Description Material / Standard
1	Body Ductile Iron / Fusion Polymeric Coated AS 1831 400-15 min / AS 4158
2	Bonnet Ductile Iron / Fusion Polymeric Coated AS 1831 400-15 / AS 4158
3	Seal Retainer Gunmetal / AS 1565 C83600
4	Gate DN 80 – DN 200 Gunmetal AS 1565 C83600 DN 225 – DN 900 Ductile Iron AS 1831 400-15
5	Spindle Stainless Steel / ASTM A276 431
6	Spindle Cap Ductile Iron / AS 1831 400-15
7	Thrust Washer Acetal
8	Body Gasket EPDM / AS 1646
9	Bonnet Gasket EPDM / AS 1646
10	Gate Nut Gunmetal / AS 1565 C83600
11	Socket Head Cap Screw and Isolation Stainless Steel / ASTM A276 316 / Silicon
12	Countersunk Screw and Isolation Stainless Steel / ASTM A276 316 / Silicon
13	Hex Head Screw Stainless Steel / ASTM A276 316
14	O-Rings Nitrile Rubber / AS 1646
15	Wiper Ring Nitrile Rubber / AS 1646
16	Seat Rings Gunmetal / AS 1565 C83600
17	Backseal Grommet Nitrile Rubber / AS 1646

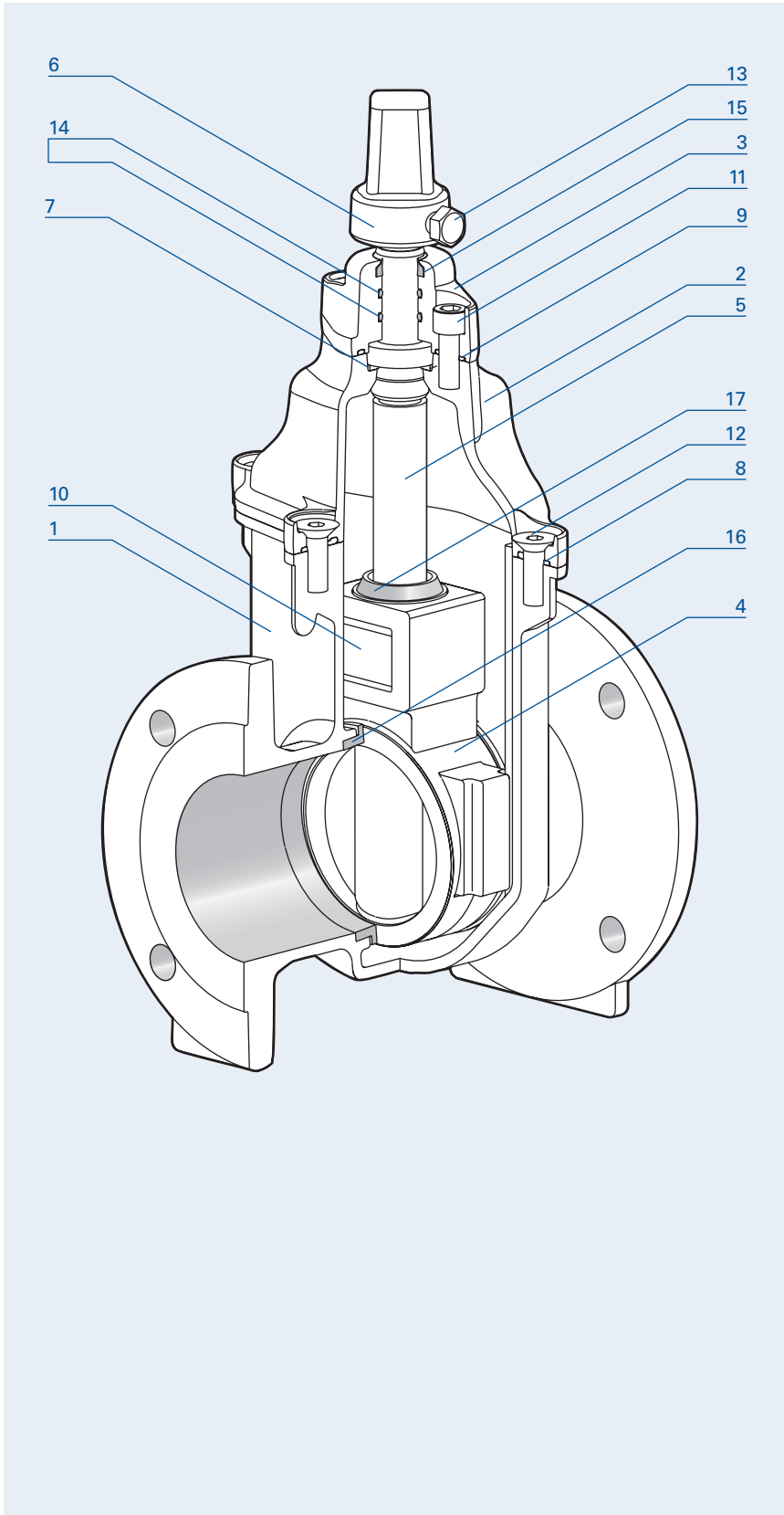

Resilient seated gate valve parts list

No	Description Material / Standard
1	Body Ductile Iron / Fusion Polymeric Coated AS 1831 400-15 min / AS 4158
2	Bonnet Ductile Iron / Fusion Polymeric Coated AS 1831 400-15 / AS 4158
3	Seal Retainer Gunmetal / AS 1565 C83600
4	Gate Ductile Iron (EPDM Encapsulated) AS 1831 400-15
5	Spindle Stainless Steel / ASTM A276 431
6	Spindle Cap Ductile Iron / AS 1831 400-15
7	Thrust Washer Acetal
8	Body Gasket EPDM / AS 1646
9	Bonnet Gasket EPDM / AS 1646
10	Gate Nut Gunmetal / AS 1565 C83600
11	Socket Head Cap Screw and Isolation Stainless Steel / ASTM A276 316 / Silicon
12	Countersunk Screw and Isolation Stainless Steel / ASTM A276 316 / Silicon
13	Hex Head Screw Stainless Steel / ASTM A276 316
14	O-Rings Nitrile Rubber / AS 1646
15	Wiper Ring Nitrile Rubber / AS 1646
16	Polymeric Coating AS/NZS 4158

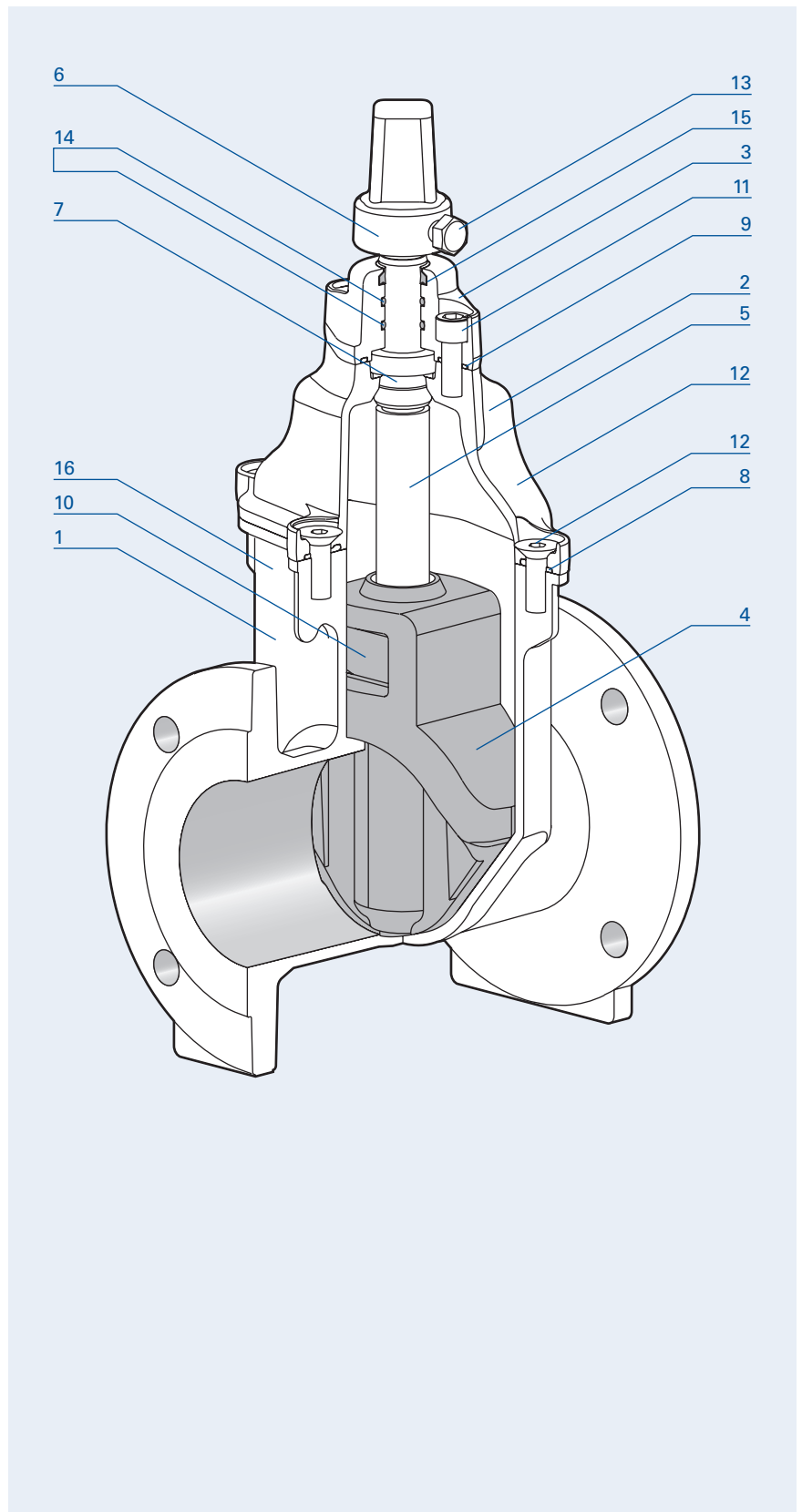

Definitions

■ Allowable Operating Pressure (AOP)

The allowable internal pressure, excluding surge, that a component can safely withstand in service

■ Allowable Site Test Pressure (ASTP)

The maximum internal hydrostatic pressure that can be applied on site to a component in a newly installed pipeline

■ Maximum allowable gearbox input torque

The maximum allowable input torque, which can be applied to a gearbox so that the output torque does not exceed the minimum strength test torque

■ Maximum Allowable Operating Pressure (MAOP)

The maximum internal pressure, including surge that a component can safely withstand in service

■ Maximum functional test torque

The maximum allowable torque to operate an ungeared gate valve at fully unbalanced allowable operating pressure

■ Maximum operator input torque

The purchaser-specified maximum operator input torque required to operate the valve or gearbox

■ Maximum possible input torque

The maximum torque that can be practically applied by an operator either manually or by mechanical means

■ Minimum strength test torque

The minimum input torque an ungeared gate valve is designed to withstand

■ Non-rising spindle design

A valve design where the gate is fixed to the spindle with a threaded nut, such that as the gate moves from closed to open position the spindle does not rise during operation

■ Pressure Classification (PN)

A classification of valves by a PN number based on the allowable operating pressure expressed in hundreds of kilopascals

■ Rising spindle design

A valve design where the gate is fixed to the spindle such that as the gate moves from closed to open position the spindle rises during operation

Allowable Pressures

PN	16	25	35
AOP	1600	2500	3500
MAOP ¹ <i>kPa</i>	1920	3000	4200
ASTP ² <i>kPa</i>	2000	3125	4375

Notes.

1. Seat leakage may occur at maximum allowable operating pressures: however, structural damage should not occur.
2. ASTP shall only be applied with the gate in the fully opened position.

The words TYTON and TYTON JOINT are United States Pipe and Foundry Co. Inc. trademarks and are registered as such in the United States Patent Office and some 45 other countries. Tyco Water is an exclusively authorised and licensed user of these trademarks within Australia and New Zealand.