

tyco

Flow Control

Tyco Water

Figure 500H and 500R Resilient Seated Gate Valves are designed and manufactured to AS 2638.2 for above ground use.

- Figure 500H non rising spindle.
- Figure 500R rising spindle (OS&Y).

Features

- Ductile iron body and bonnet for high strength and impact resistance.
- Ductile iron gate fully encapsulated in EPDM rubber to ensure drop tight sealing.
- Grade 431 Stainless Steel spindle for high strength and corrosion resistance.
- Gunmetal dezincification resistant top casting incorporating dual O-ring seals and wiper ring for long life operation.
- Back seal facility to allow for replacement of seals under full operating pressure.
- Rilsan® Nylon 11 coating for long life corrosion protection.
- Straight through full bore to avoid debris traps.
- Isolated fasteners for corrosion protection.
- Anti-friction thrust washer for low operating torques.
- Integral cast in feet for safe and easy storage.
- Integral lifting lugs for installation convenience.
- Hand wheel operation.



General Application

Figure 500H & 500R resilient seated gate valves are suitable for use with water or waste water, in above ground applications. Rising spindle gate valves are commonly used in fire service applications where a positive indication of open or closed position is necessary.

Technical Data

Size Range: DN80-DN300
Allowable Operating Pressure: 1600 kPa
Maximum Temperature: 40°C
End Connections: Flanged to AS 2129 TE or AS 4087 Fig B5 (TC compatible)
Certification: ISC AS 2638 Product Mark Registration No. PRD/R61/0412/2

Resilient Seated Gate Valves - Fig. 500H & 500R

DN80 - DN300

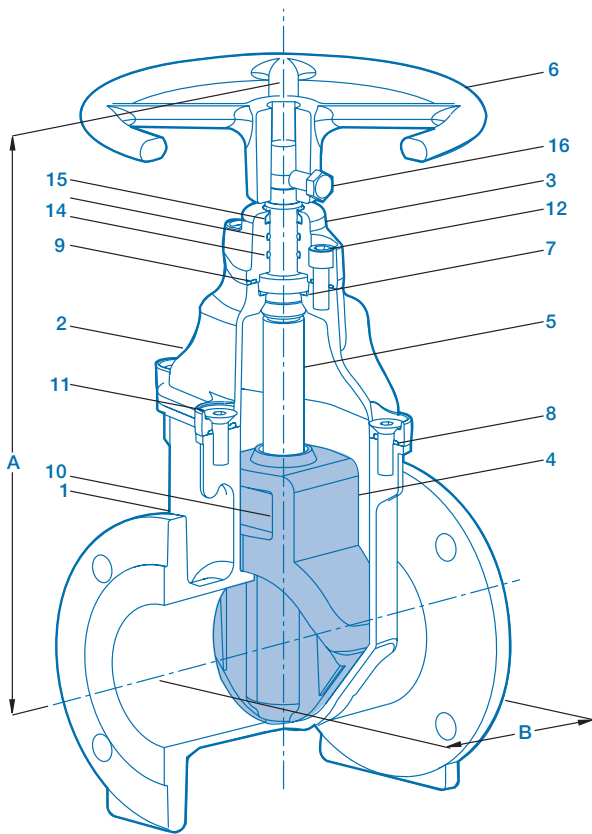

Note: F500H illustrated.

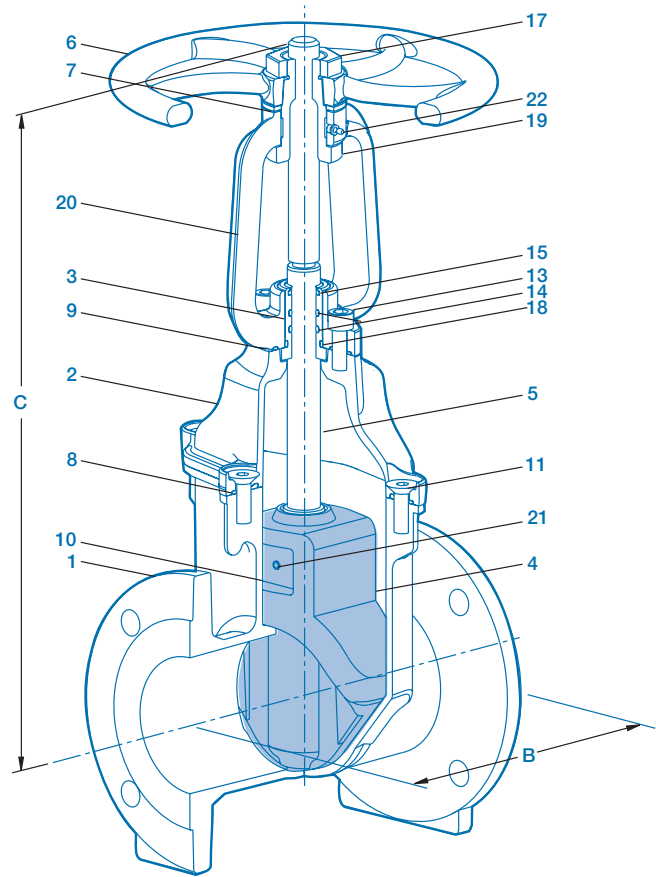

Note: F500R illustrated.

Parts List

No	Description	Material	Standard
1	Body	Ductile Iron	AS 1831 400-12
2	Bonnet	Ductile Iron	AS 1831 400-12
3	Seal Retainer	Gunmetal	AS 1565 C83600
4	Gate	Ductile Iron (EPDM Encapsulated)	AS 1831 400-12
5	Spindle	Stainless Steel	ASTM A 276 316
6	Handwheel	Ductile Iron	AS 1831 400-12
7	Thrust Washer	Acetyl	-
8	Body Gasket	EPDM	AS 1646
9	Bonnet Gasket	EPDM	AS 1646
10	Gate Nut	Gunmetal	AS 1565 C83600
11	Countersunk Screws	High Tensile Alloy Steel	-
12	Socket Head Screws	High Tensile Alloy Steel	-
13	Socket Head Cap Screw	Stainless Steel	ASTM A276 316
14	O-Rings	Nitrile Rubber	AS 1646
15	Wiper Ring	Nitrile Rubber	AS 1646
16	Hex Head Screw	Stainless Steel	ASTM A276 316
17	Locknut	Galvanised Malleable Iron	-
18	'O' Ring	Nitrile Rubber	AS 1646
19	Drive Nut, Handwheel	Gunmetal	AS 1565 C83600
20	Yoke	Ductile Iron	AS 1831 400-12
21	Roll Pin	Stainless Steel	ASTM A276 316
22	Grease Nipple	Zinc Plated Mild Steel	-
23	Fusion Coating	Rilsan Nylon 11	AS/NZS 4158

Dimensions (mm)

Valve Size	A	B	C	
			Open	Closed
80	367	203	512	425
100	402	229	590	483
150	502	267	788	630
200	610	292	930	722
250	723	330	1200	940
300	810	356	1390	1080