



These Figure 600 Metal Seated Gate Valves with shouldered spigot ends, feature a non-rising spindle. Designed and manufactured to AS 2638.1

Features

- Non-rising spindle.
- Ductile Iron body and bonnet for high strength and impact resistance.
- Solid gunmetal gate.
- Grade 431 stainless steel spindle for high strength and corrosion resistance.
- Gunmetal dezincification resistant top casting incorporating dual O-ring seals and wiper ring for long life operation.
- Back seal facility to allow for replacement of seals under full operating pressure.
- Red Oxide coating.
- Isolated fasteners for corrosion protection.
- Anti-friction thrust washer for low operating torques.
- Integral cast feet for safe and easy storage.
- Handwheel Operation.



General Application

Figure 600 metal seated gate valves are suitable for use with water or waste water applications. Shouldered spigot end gate valves are commonly used in mining and fire service applications.

Technical Data

Size Range: DN100 - DN150
Allowable Operating Pressure: 3500 kPa
Maximum Temperature: 40°C
End Connections: Shouldered Spigot
Standards: AS 2638.1 - Gate Valves for Waterworks Purposes
Certification: ProductMark Licence PRD/R61/0412/2

Metal Seated Gate Valves - Shouldered Spigot

DN100 - DN150

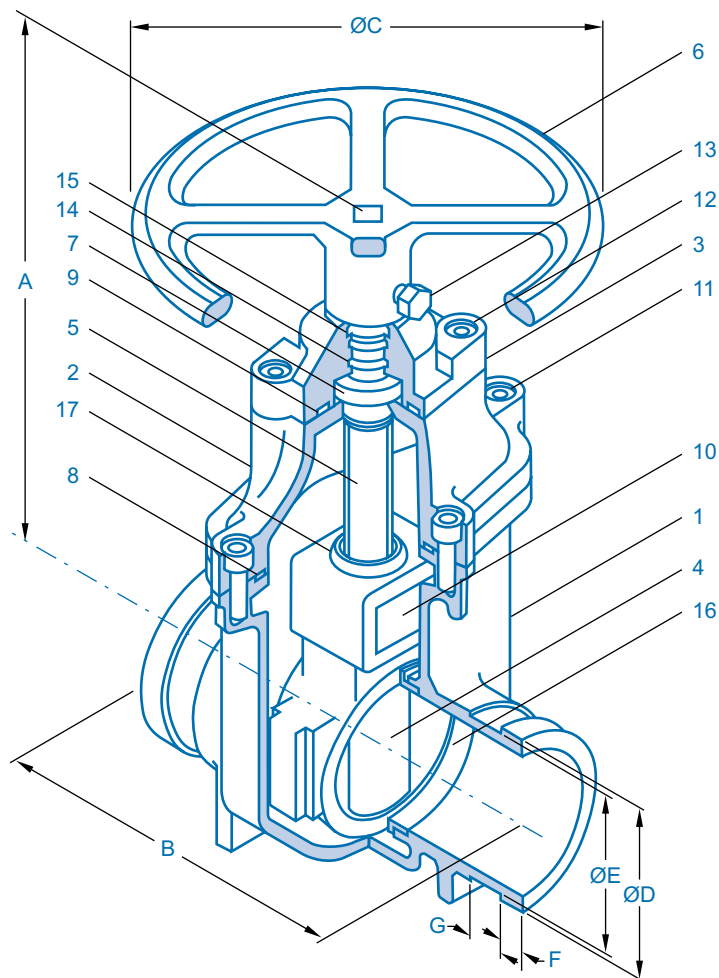

Parts List

No	Description	Material	Standard
1	Body	Ductile Iron	AS 1831-400/15
2	Bonnet	Ductile Iron	AS 1831-400/15
3	Seal Retainer	Gun Metal	AS 1565 C83600
4	Gate	Gun Metal	AS 1565 C83600
5	Spindle	Stainless Steel	ASTM A276 431
6	Handwheel	Ductile Iron	AS 1831-400/15
7	Thrust Washer	Acetyl	-
8	Body Gasket	EPDM Rubber	AS 1646
9	Bonnet Gasket	EPDM Rubber	AS 1646
10	Gate Nut	Gunmetal	AS 1565 C83600
11	Countersunk Cap Screw	High Tensile Alloy Steel	-
12	Socket Head Cap Screw	High Tensile Alloy Steel	-
13	Hex Head Screw	Stainless Steel	ASTM A276 431
14	O-Ring	Nitrile Rubber	AS 1646
15	Wiper Ring	Nitrile Rubber	AS1646
16	Body Ring	Gun Metal	AS 1565 C83600
17	Backseal Grommet	Nitrile Rubber	AS 1646

Dimensions (mm)

DN	A (height)	B (length)	ØC (handwheel)	ØD	ØE	F	G
100	400	230	275	122.2	114.3	17.5	24.5
150	490	270	275	175.1	165.1	17.5	38.5